

NOTICE CONFIDENTIAL PROPERTY

ALL INFORMATION & DRAWINGS CONTAINED HEREIN ARE THE SOLE CONFIDENTIAL PROPERTY OF HUB PLASTICS INC. REPRODUCTION OF THIS MATTER IN WHOLE OR IN PART IS FORBIDDEN WITHOUT THE EXPRESS WRITTEN CONSENT OF HUB PLASTICS INC.

SYM.	DATE	REVISIONS
1	9.15.92	REMOVE L.D.P.E SPEC.
2	1.16.94	CHANGE H & S DIM.
3	1.18.95	ADDED SEAL BEAD DIM.
4	7.15.02	REDRAWN IN SOLIDWORKS.
5	7.16.02	CORRECT HEIGHT DIM.(TO MATCH PART)

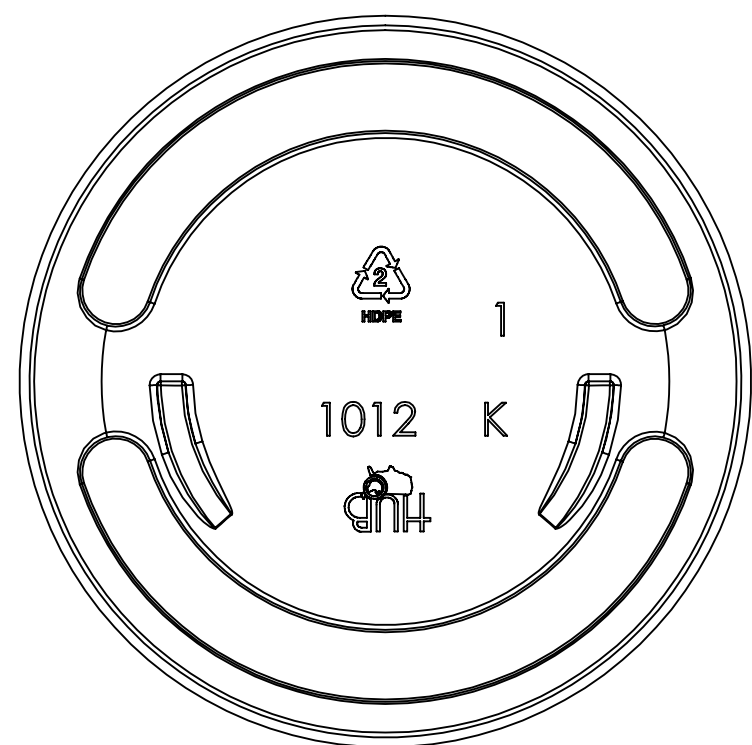
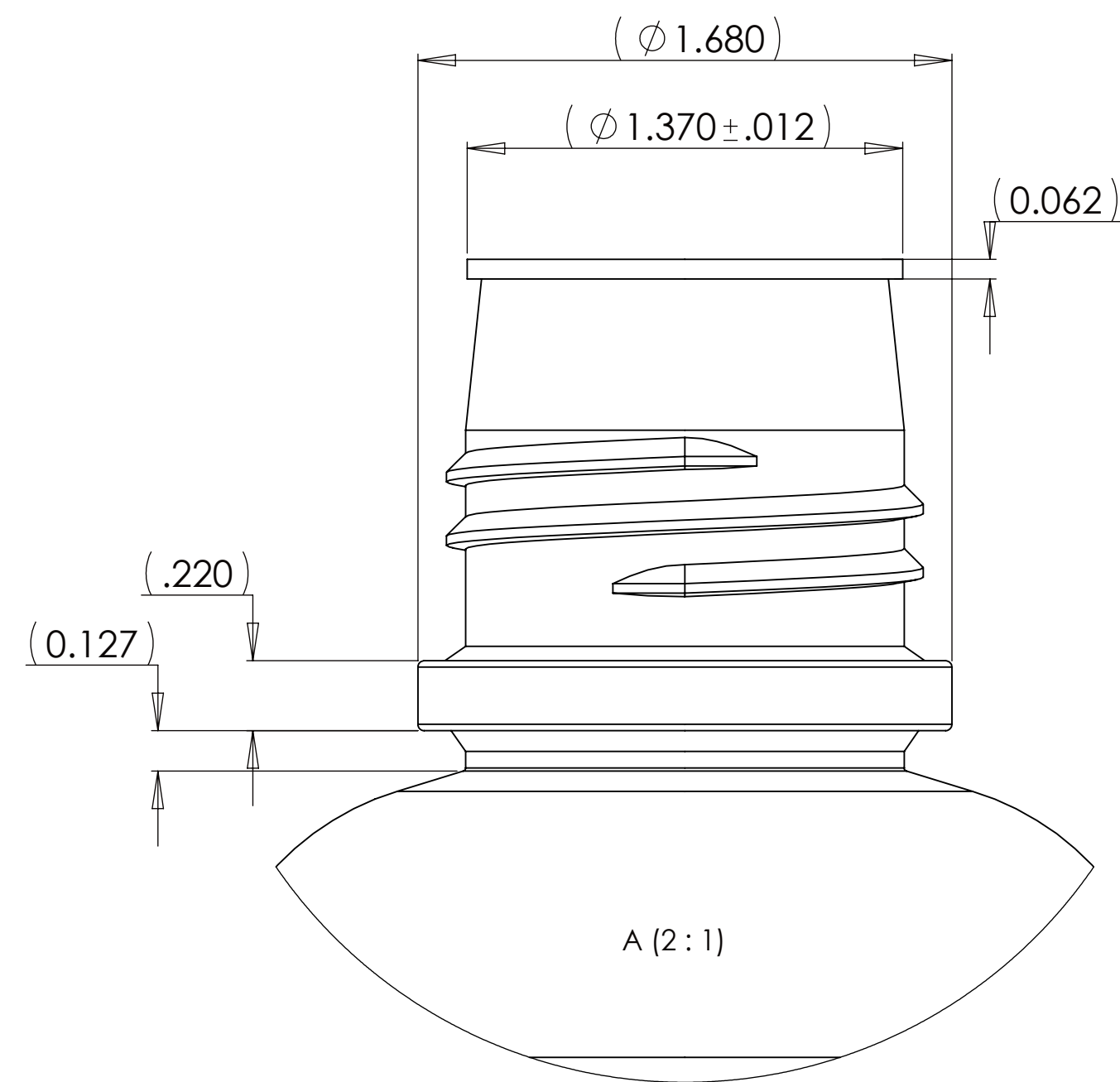
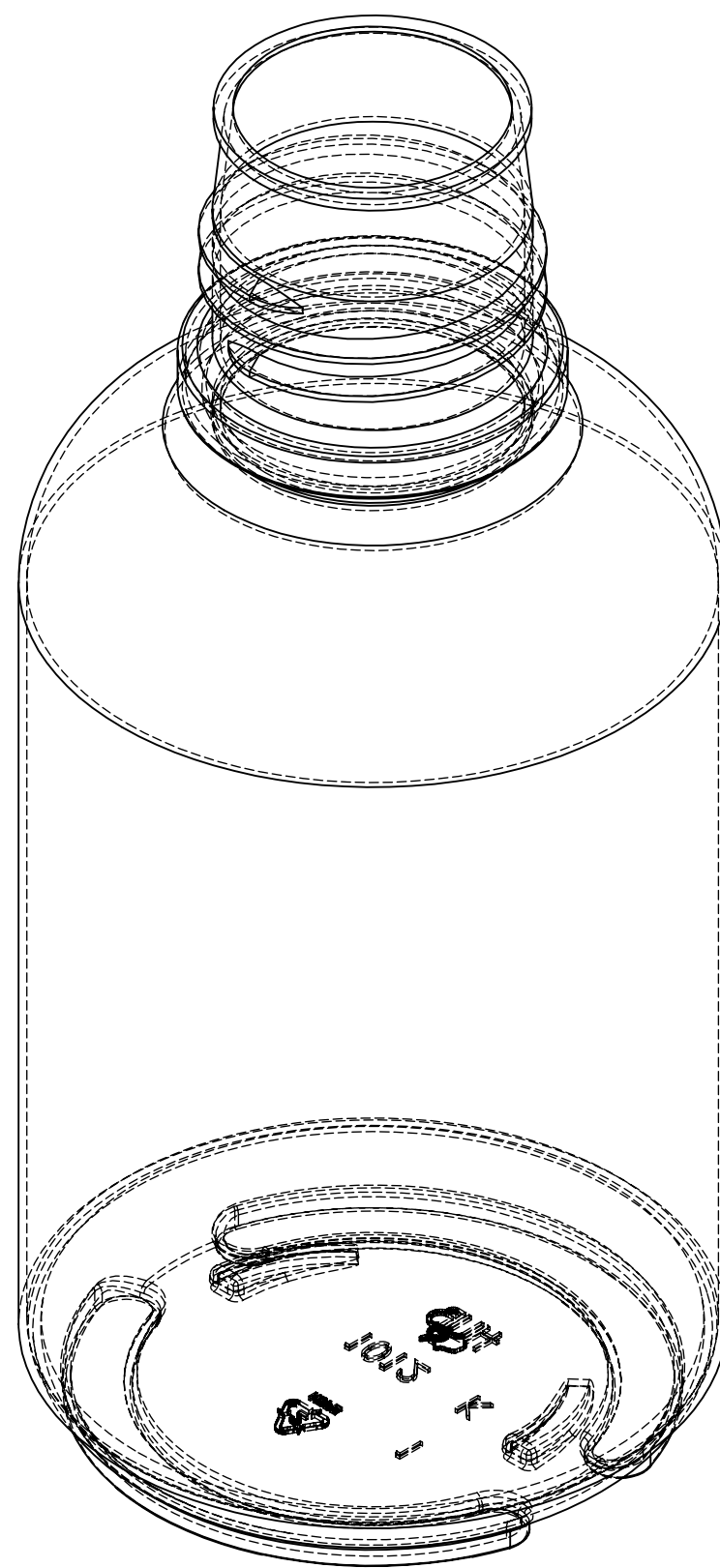
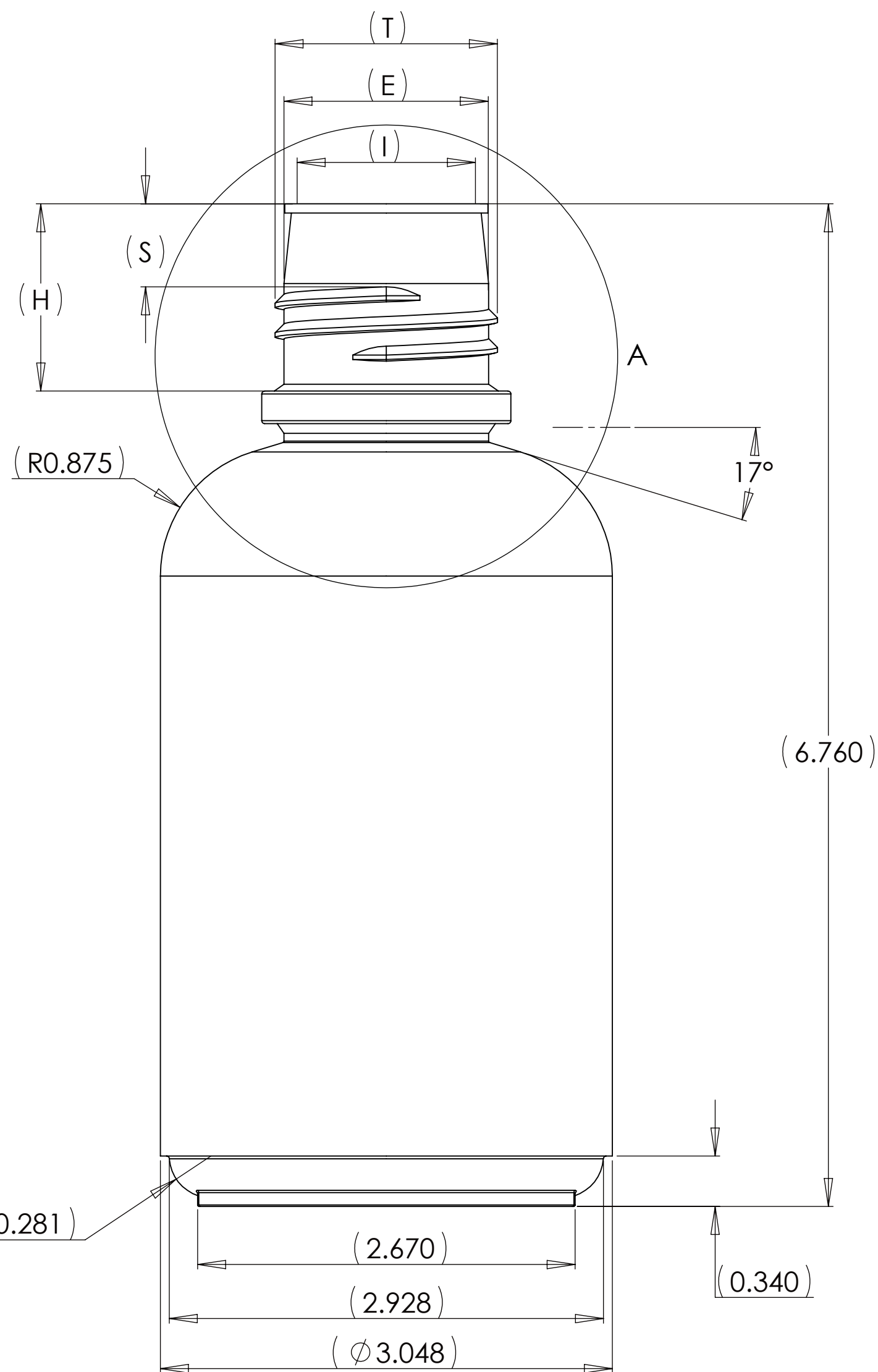

38-430 5 Pitch neck finish		
SYM.	MAX.	MIN.
T	1.512	1.488
E	1.392	1.368
H	1.262	1.232
S	.575	.545
I	0.000	1.125
Seal Bead	1.382	1.358

16oz. BOSTON ROUND
HUB PLASTICS INC.
 DRAWN BY MW SCALE 1.25-1 MATERIAL HDPE
 CHK'D DATE 7.15.02 DRAWING NO. 1012-050
 TRACED APP'D

TOLERANCES	REVISIONS		
	NO.	DATE	BY
DECIMAL ± .000	1	9.15.92	CCA
HEIGHT ± .060	2	11.16.94	CCA
WIDTH&DEPTH ± .060	3	1.18.95	CCA
	4	7.15.2002	MW
	5	7.16.02	MW