

IF YOU...



MIX IT. FILL IT. PACK IT. SHIP IT.

WE HAVE A PRODUCT FOR YOU



Part #	26W82B
Capacity	5 gal.
Color	Black
Material	Steel
Closure	Tight Head (Closed)
Lining	Rust Inhibitor Enamel
Steel Gauge	24/24/24 (Top/Body/Bottom)
Fittings	2-1/8" Spout & Cap
Dimensions	10-15/16" Dia. (top) x 11-7/16" Dia. (bottom) x 13-1/2"H
UN Rating Liquid	UN1A1/Y1.8/170

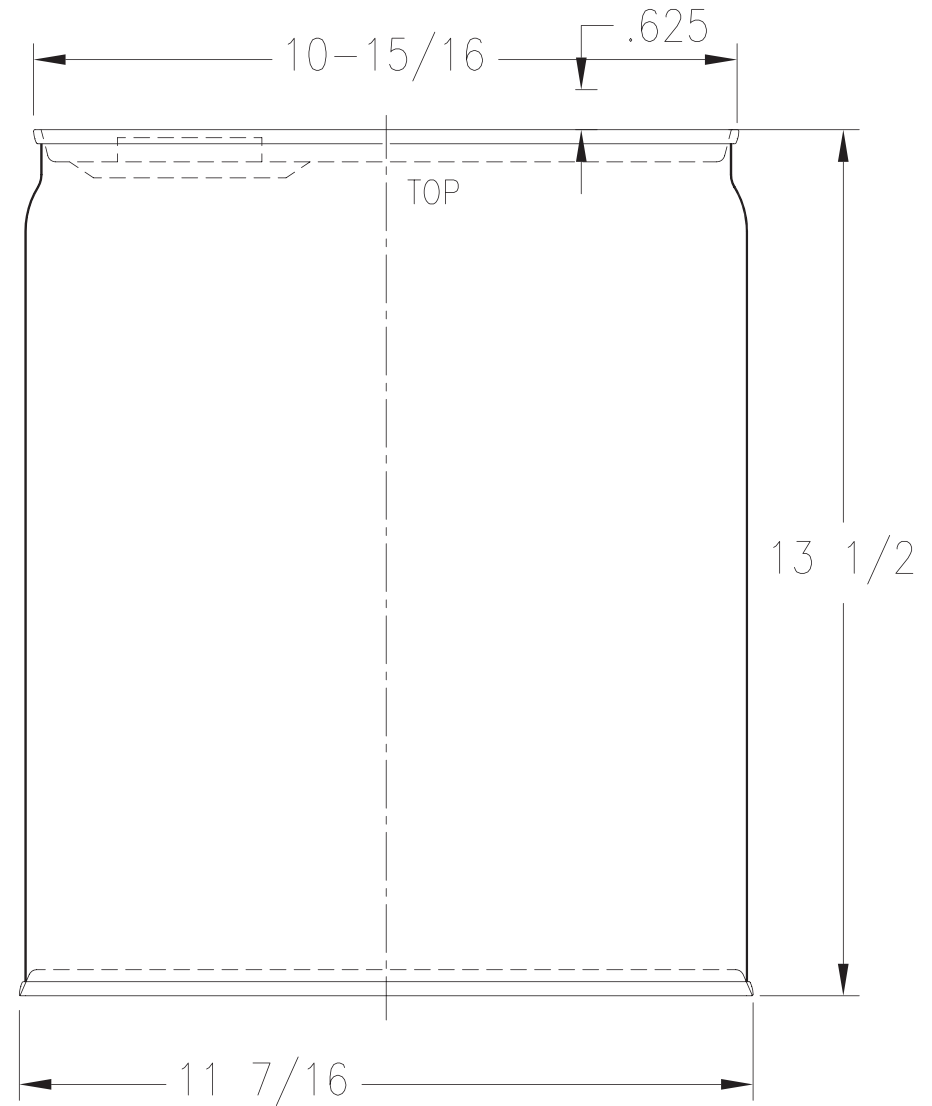
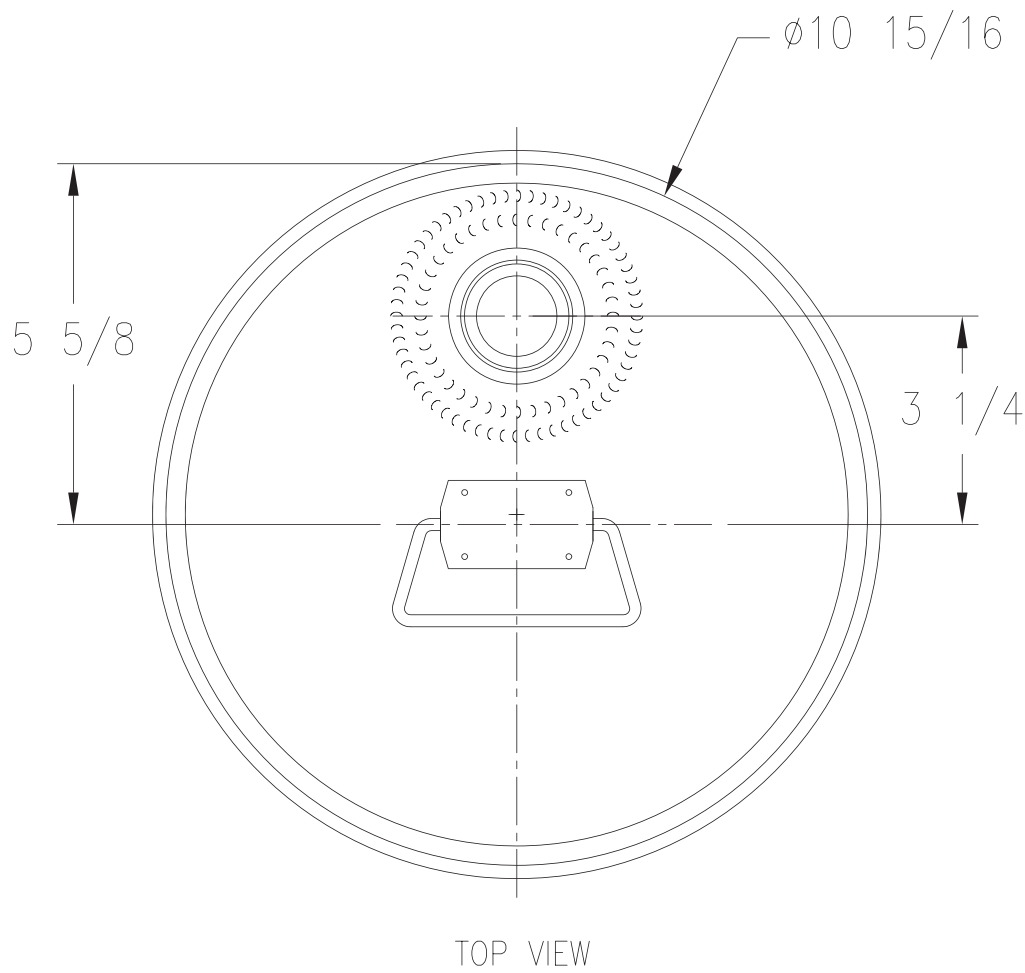

Supplied By: **The Cary Company**
 Ph: 630-629-6600
www.thecarycompany.com

11-1/4" DIAMETER - 5 GALLON
 CLOSE TOP, STRAIGHT SIDED PAIL
 WITH 2-1/8" SCREW FITTING

DRAWN BY:	SCALE	REV. BY	NO.	DATE	REVISION DESCRIPTION
J.Zavala	NONE				
CHECKED BY:	DATE				
	3-20-12				
APPROVED BY:					

LOCATION
 CHICAGO

SUPERCEDES
 6245

MATERIAL

PRINT NO.
 PD500-5-071

REV.